



Рей Rolle
Protection
Devices

7PG17 – XR 250/1 & 350/1

Supervision Relays

Answers for energy

SIEMENS
SIEMENS
siemens-russia.com

7PG17– XR250, XR251, XR350, XR351

Supervision Relays

Description

Supervision relays are attached armature relays developed from the AR auxiliary relay series:

XR250 Two elements and a self reset flag
XR251 Two elements and a hand reset flag
XR350 Three elements and a self reset flag
XR351 Three elements and hand reset flag

These XR relays are designed to meet the requirements of BEBS S15 schemes for trip circuit supervision. They are also suitable for trip relay supervision. Typical applications are illustrated.

Safety

The commissioning and future maintenance of this equipment should only be carried out by skilled personnel trained in protective relay operation and capable of observing all the necessary safety precautions and regulations appropriate to this equipment and also the associated primary plant.

Equipment should be isolated from auxiliary supplies and the circuit breaker trip circuit prior to commencing any work on an installed product.

Unpacking, handling & storage

On receipt unpack the relay and inspect for any obvious damage. It is not normally necessary to remove the relay from its polythene bag unless some damage is suspected or if it is required for immediate use.

If damage has been sustained a claim should immediately be made against the carrier, also inform Siemens Protection Devices Limited.

When not immediately required return the relay to its carton and store in a clean, dry place.

Preliminary Tests

Check that the operating voltage is correct for the auxiliary voltage to be used. In some instances relays are to be used with the coil in series with a voltage dropper resistor, this is advised on our Order Acknowledgement and

shown on the relay label as "+Ext R", suitable resistors are supplied with the relay, ensure that such resistors are mounted vertical, are secure and wired to the correct relay coil.

If the relay is wired into the circuit isolate from the auxiliary supply by removing fuses and links as necessary.

Physically check the wiring to the relay terminals for security and that it is correct to the relay wiring diagram and circuit schematic/wiring diagrams.

Insulation Tests

Using a 500V insulation test set:

- a) Connect all relay terminals together and measure the resistance to earth
- b) Connect the d.c. input terminals together and measure the resistance between these terminals and all other terminals connected together and to earth.
- c) Connect the relay output contacts together and measure the resistance between these terminals and all other terminals connected together including earth.

A value of 2.5 to 3.0 megohms obtained from the above tests is considered satisfactory, a value of less than 1.0 megaohm is not satisfactory and the cause of such a low reading should be determined and corrected.

Mechanical Settings

It should not be necessary to adjust settings during routine tests unless parts have been replaced or other repairs carried out. Adjustment of one setting will often influence another, therefore all settings must be checked after the final adjustment.

The table of Mechanical Settings provides the basic settings necessary before finally setting the relay to obtain its performance and are generally minimum values.

Electrical Tests

Check that the relay operates over its operating range, it should operate smoothly and the armature go fully home.

Operating Range

D.C. relays, 80% to 120% of rated voltage
Relays have a delayed reset time of 400ms when the supply is switched off from rated voltage.
Remove test leads and replace any isolation links

Maintenance

The maintenance tests required will largely depend upon experience and site conditions. As a general recommendation these tests should be carried out at yearly intervals.

Mechanical settings			
1. Residual gap	1.1	Measured at top of core.	zero
2. Armature gap	2.1	Measured at residual screw: Elements A and B Element C	1.5mm 1.8mm
3. Normally closed contacts	3.1	Clearance between comb and moving contact.	0.1-0.2mm
	3.2	Force to separate closed contacts, gms	12-15 gm
	3.3	Force required to lift fixed contact off its backing strip, gms	8-10 gm
	3.4	Contact separation	1.6mm
4 Normally open contacts	4.1	Remaining armature travel, measured at the residual screw	0.35mm
	4.2	Contact separation	1.6mm min
	4.3	Force required to lift moving contact off the comb, gms	8-10gm
	4.4	Force required to lift the fixed contact off it's backing strip, gms	8-10gm
5 Armature control Spring	5.1	Only fitted to certain relays When there are no normally open contacts With 1 normally open contact	10-12 gm 6-8 gm

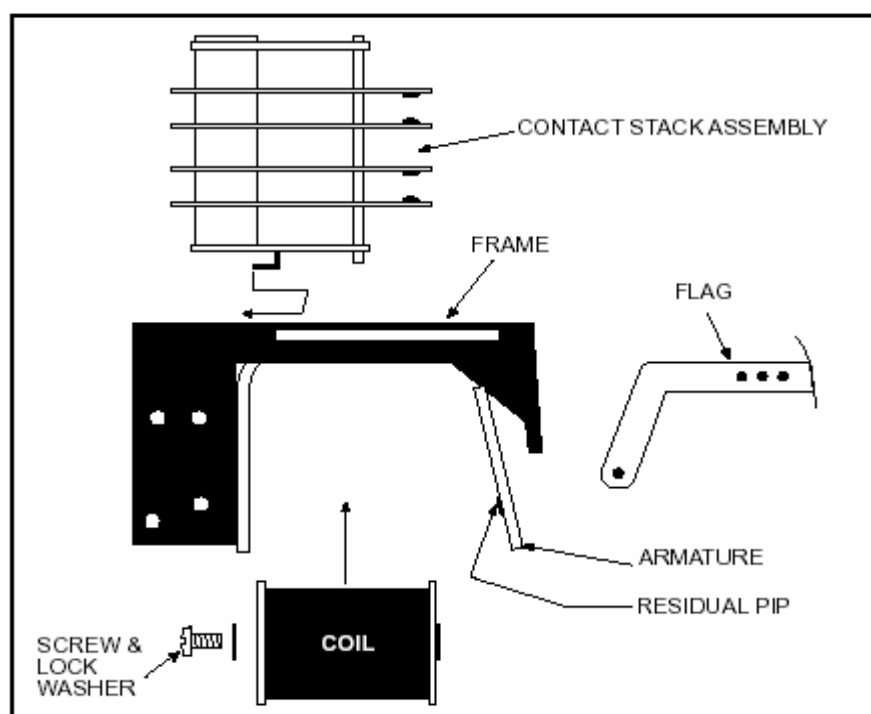

Typical relay sub-assemblies.

Application Diagrams

Trip Relay supervision XR250/1, Latching Trip Relay:

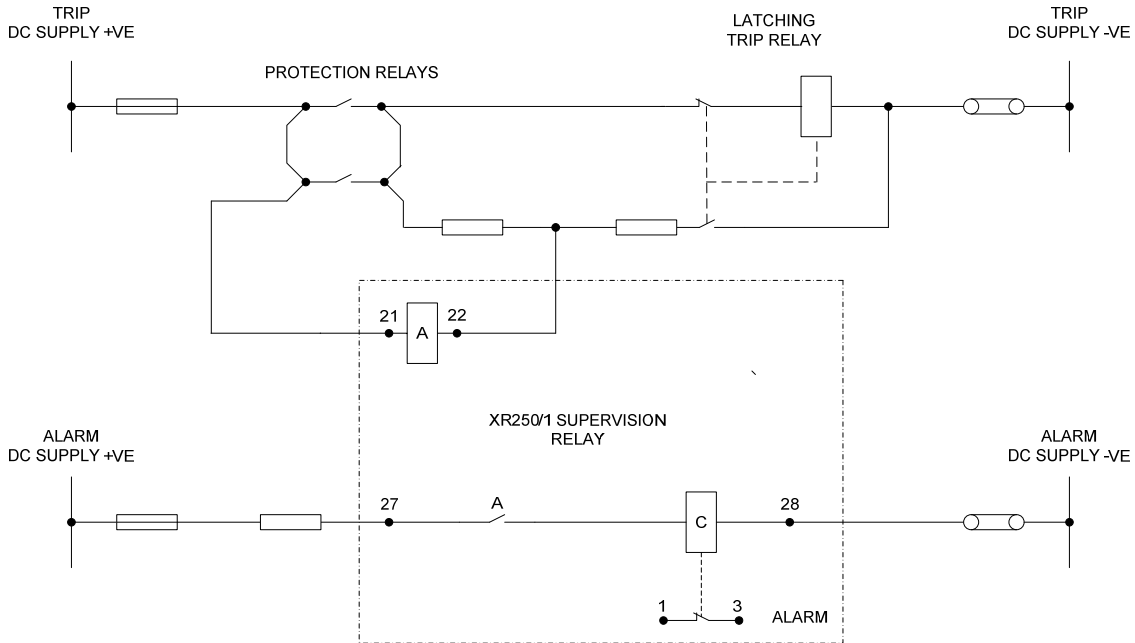

Trip Relay supervision XR250/1, Self Reset Trip Relay:

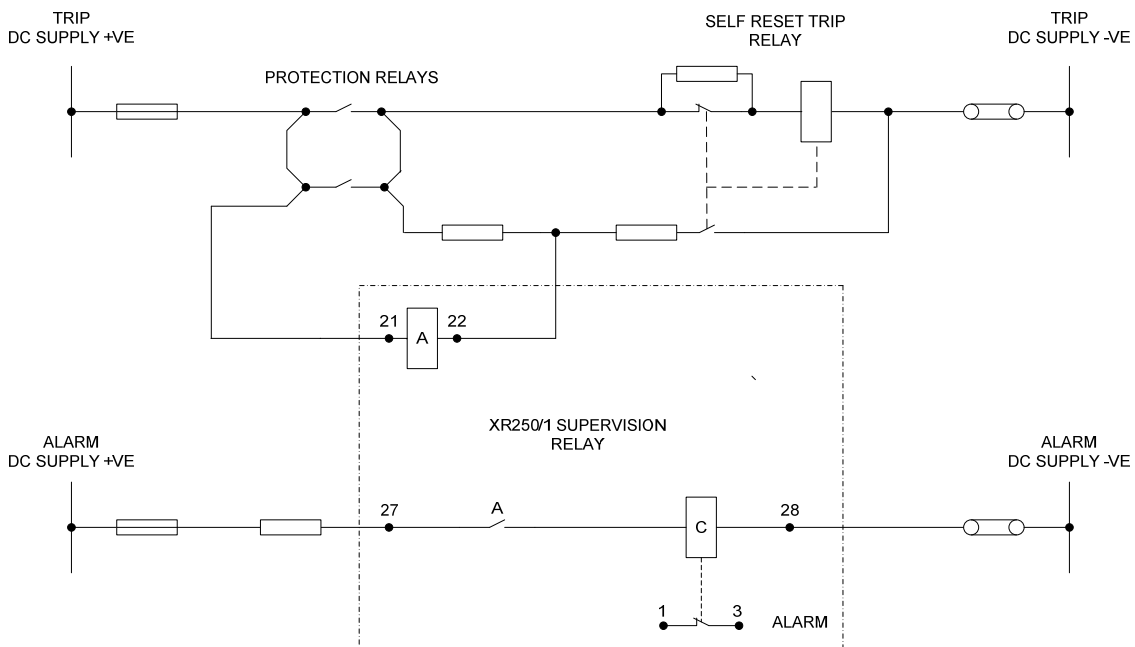

Trip Circuit supervision XR250/1:

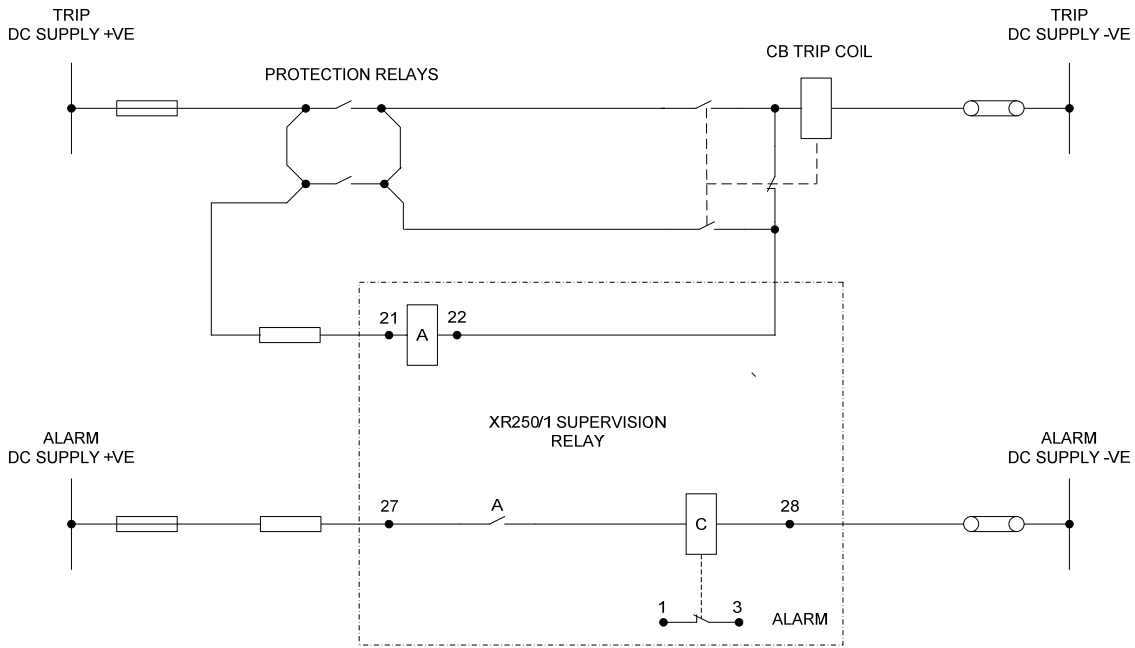

Trip Circuit supervision XR350/1:

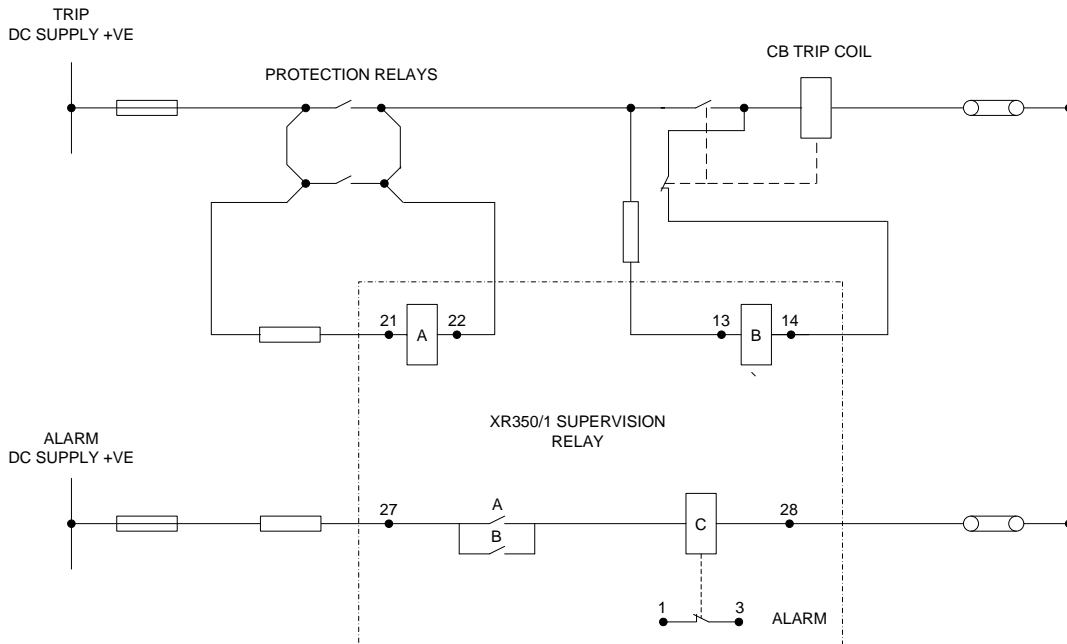

Published by and copyright © 2010:
Siemens AG
Energy Sector
Freyeslebenstrasse 1
91058 Erlangen, Germany

Siemens Protection Devices Limited
P.O. Box 8
North Farm Road
Hebburn
Tyne & Wear
NE31 1TZ
United Kingdom
Phone: +44 (0)191 401 7901
Fax: +44 (0)191 401 5575
www.siemens.com/energy

For more information, please contact our
Customer Support Center.
Phone: +49 180/524 70 00
Fax: +49 180/524 24 71 (Charges depending on provider)
E-mail: support.energy@siemens.com

Power Distribution Division Order No. C53000-G7076-C61-1
Printed in Fürth

Printed on elementary chlorine-free bleached paper.

All rights reserved.

Trademarks mentioned in this document are the property of Siemens AG, its affiliates, or their respective owners.

Subject to change without prior notice.

The information in this document contains general descriptions of the technical options available, which may not apply in all cases. The required technical options should therefore be specified in the contract.